



PROJECT DESIGN - 3x6x2.7m attached pergola N2 windzone

Welcome to Design Pine Projects, we have taken the hassle out of designing your simple pergola as we have done all the work. The attached plan specifies the timber sizes needed and a cutting list for lengths required.

The specified project has been designed for use in following location:

- Wind Zone – N2
- Maximum roof load- Light Roof (10kg/m²) - Steel sheet roof with battens

The design of the timber components has been carried out in accordance with the relevant Australian standards. All consents, construction methods and connections are to be in accordance of the Australian Building Code or local authorities. Some connections and foundations may require additional specific design. Design Pine uses an organic preservation system to H3, this makes it ideal for all above ground exterior applications but is not to be put in direct contact with the ground surface or embedded in the ground.

Engineering Certified By:

David King ME(Civil) MIPENZ CPEng IntPE No 145511

Tasman Consulting Engineers

PO Box 3631, Richmond, NELSON 7050, NEW ZEALAND

CUTTING LIST FOR THIS PRODUCT

Below is the list of all the timber requirements to construct this plan, The 'Cut for plan' column outlines what each piece needs to be cut to suit this plan and the 'Kit Contains' column shows what Design Pine you will receive in order to make your cuts with minimal waste.

3.0 x 6.0 x 2.7 attached pergola N2 wind zone				Cut for plan		Kit Contains	
#	Application	Size	Product Description	Length (mm)	Quantity	Length (mm)	Quantity
A	Posts	88x88	88x88 Design Pine GL8 Post	2700	4	2700	4
B	Rafters	90x42	90x42 Design Pine F7	1980	13	4200	7
B	Rafters	90x42	90x42 Design Pine F7	1980	1	3600*	1*
C	Front edge beams	138x42	138x42 Design Pine F7	3000	1	3000*	1*
D	Rear edge beams	138x42	138x42 Design Pine F7	3000	1	3000*	1*
E	Edge beams	185x42	185x42 Design Pine F7	6000	2	6000	2
F	Center beam	138x42	138x42 Design Pine F7	3000	1	3600	1
G	Ridge beam	185x42	185x42 Design Pine F7	6000	1	6000	1
H	Vertical supports	90x42	90x42 Design Pine F7	710	1	1200*	1*
I	Corner brace	90x42	90x42 Design Pine F7	900	4	3600	1
J	Battens	66x42	66x42 Design Pine F7	6000	6	6000	6
				* Front and rear edge beam supplied as 1 x 6000 length. Vertical support is to be cut from the offset of the 3600 length of the 90x42 rafter			

NOTES:

1. Wind loads have been derived from AS4055-1992, wind loads for housing, with the net pressure coefficients (cpn) being C 1.5 and +0.07.
2. Stress grade of laminated 65mm boards to GL8 or GL10 and 30mm or 42mm board to F7.
3. Beams designed to provisions of AS 1720:1997, Timber Structures, and AS1170.0:2002 Structural Design Actions.
4. Timber design in accordance with AS1720.1.
5. All construction and connections to comply with the Australian Building Code.
6. Specific design may be required for some connections and for the foundations.
7. No responsibility is taken for incorrect construction.

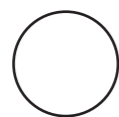
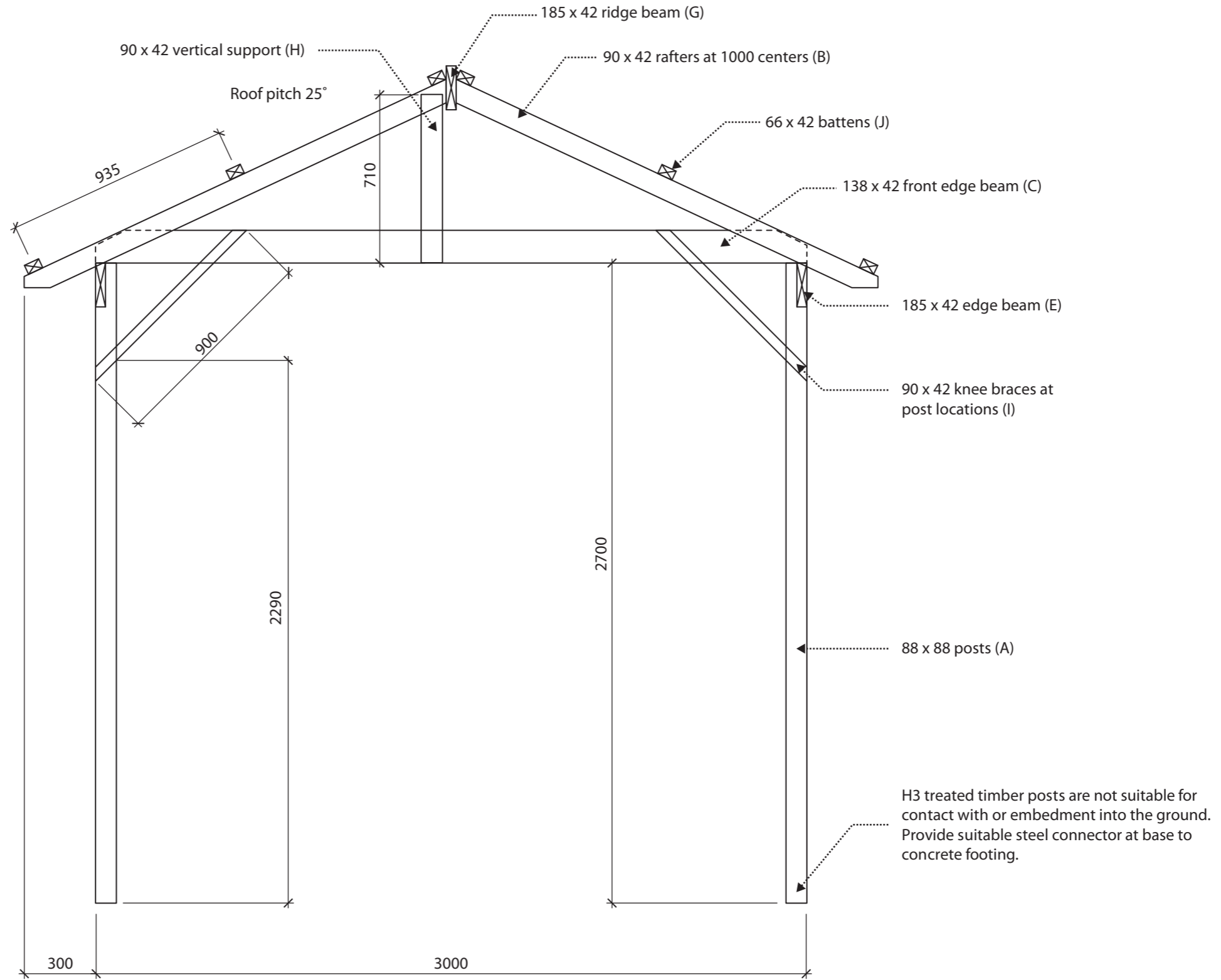

FRONT ELEVATION

N2 WIND

NOTES:

1. Wind loads have been derived from AS4055-1992, wind loads for housing, with the net pressure coefficients (cpn) being C 1.5 and +0.07.
2. Stress grade of laminated 65mm boards to GL8 or GL10 and 30mm or 42mm board to F7.
3. Beams designed to provisions of AS 1720:1997, Timber Structures, and AS1170.0:2002 Structural Design Actions.
4. Timber design in accordance with AS1720.1.
5. All construction and connections to comply with the Australian Building Code.
6. Specific design may be required for some connections and for the foundations.
7. No responsibility is taken for incorrect construction.

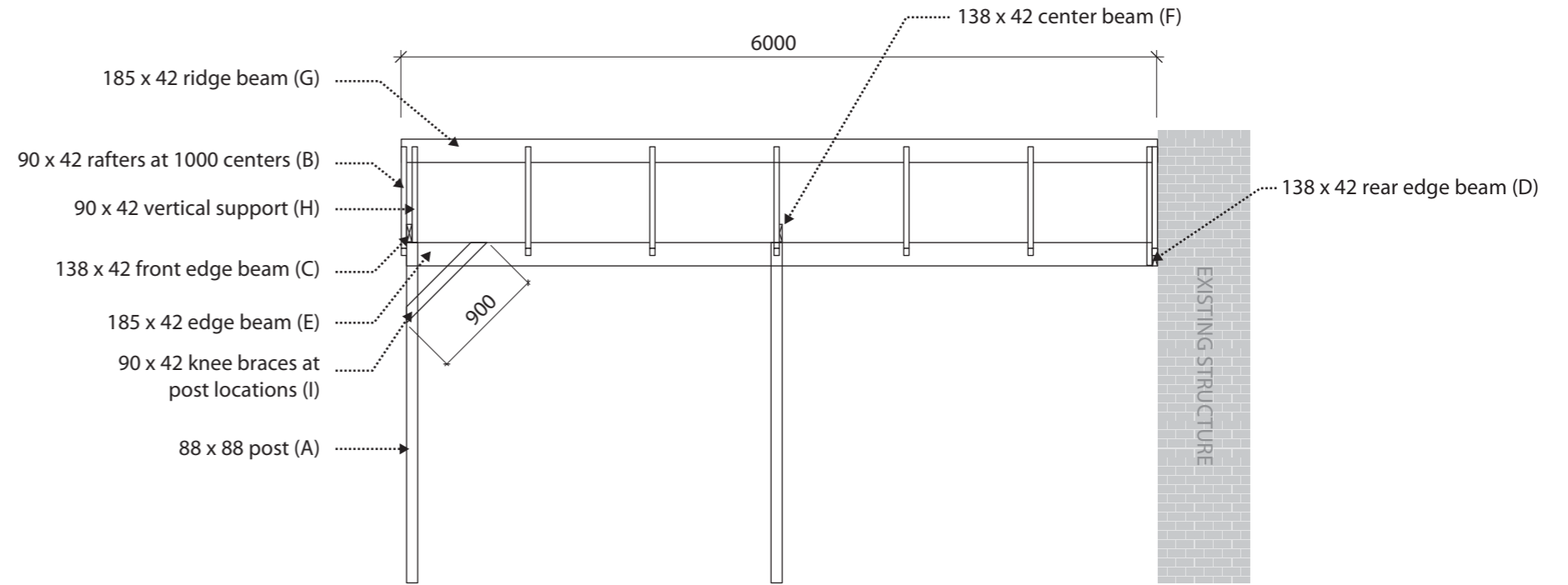

○ SIDE ELEVATION - BATTENS NOT SHOWN

N2 WIND

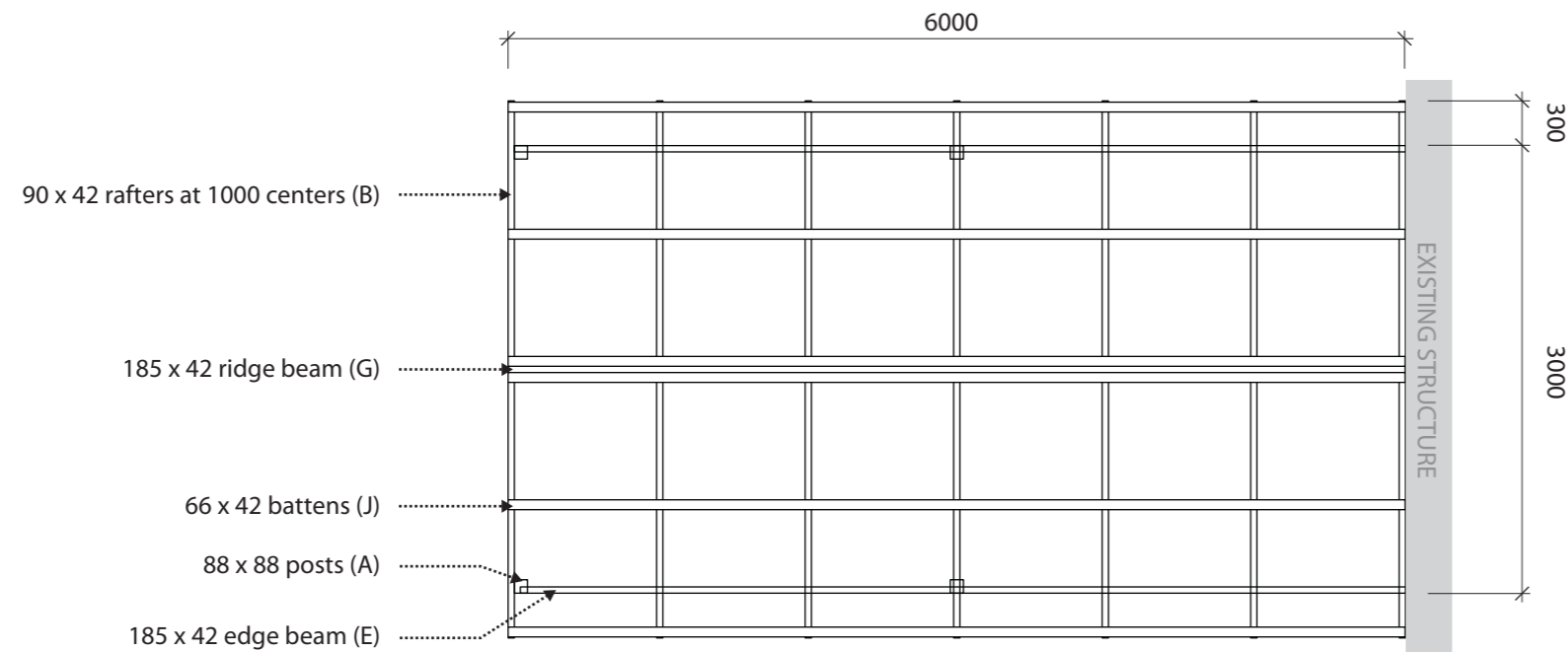

○ ROOF PLAN

N2 WIND